

## CB-5002 TO CB-5003 Rework instructions for board conversion in 29000 series units.

**WARNING!!! DISCONNECT ALL POWER COMING TO MACHINE BEFORE STARTING ANY WORK**

Instructions for converting any 29000 series unit with CB-5002 to new board CB-5003. Instructions are for board swap which will apply to any 29000 series. Page 7 is additional instructions for Turbo Towel modifications, models 29050 and 29051 only. Page 8 involves reworking 29000, 29001, 29002, 29003, 29060, 29061, 29062, 29063 machines with new shampoo and spot remover pump kits only. Remaining pages detail reusing pumps in same models but converting harness for Shampoo and Spot Remover pumps.

### INDEX

Page 1-6: Board conversion All 29000 series

Page 7: Turbo Towel rework, 29050 and 29051 only

Page 8: Converting pumps on 29000, 29001, 29002, 29003, 29060, 29061, 29062, 29063 using new pump kits 29000-29A-5 or 29060-29A-1

Page 9-14: Converting pumps on 29000, 29001, 29002, 29003, 29060, 29061, 29062, 29063 using existing pumps with new wire harness CB-03-SHAMP

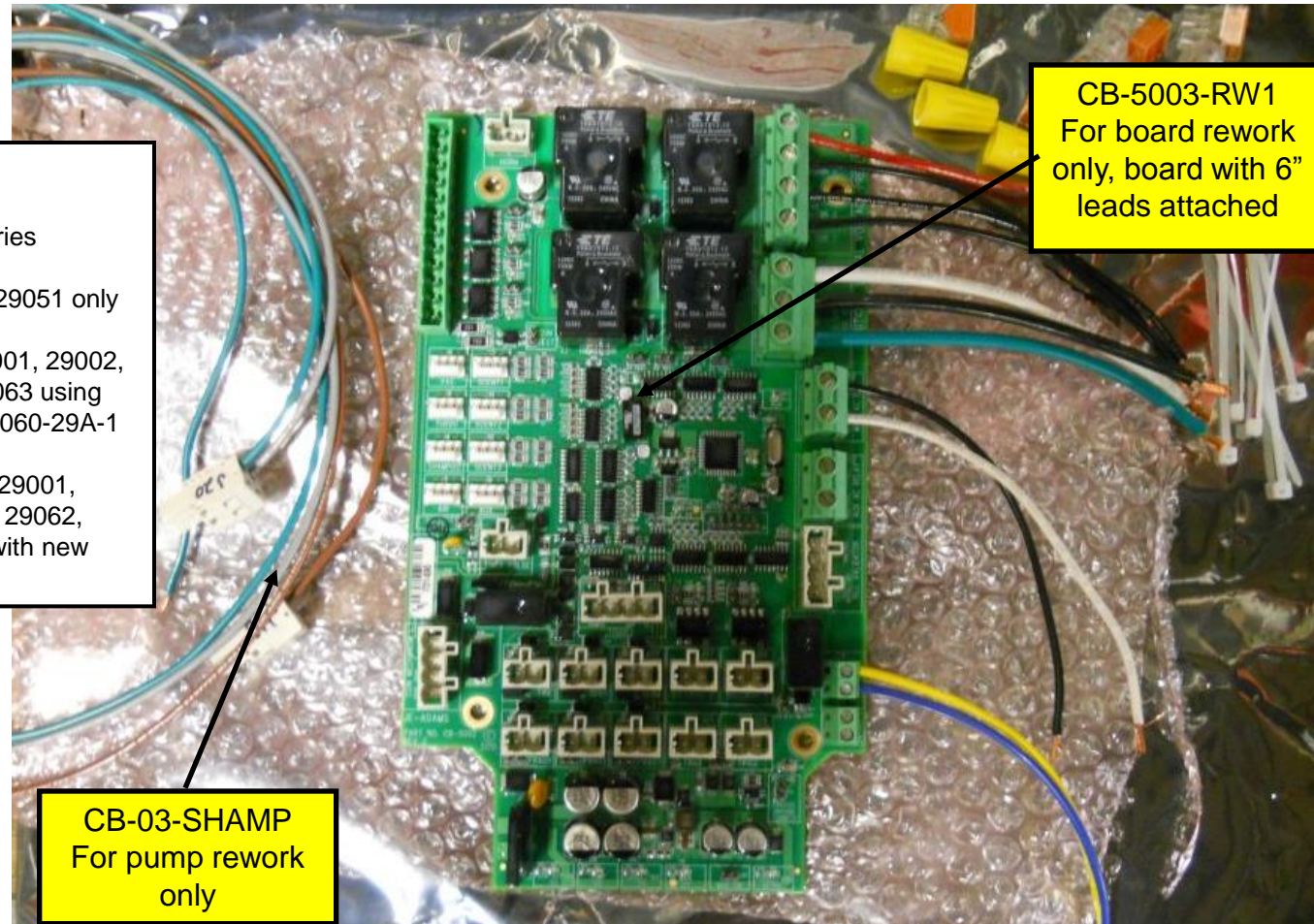

CB-5003-RW1  
For board rework  
only, board with 6"  
leads attached

CB-03-SHAMP  
For pump rework  
only

**WARNING!!! DISCONNECT ALL POWER COMING TO MACHINE BEFORE STARTING ANY WORK**

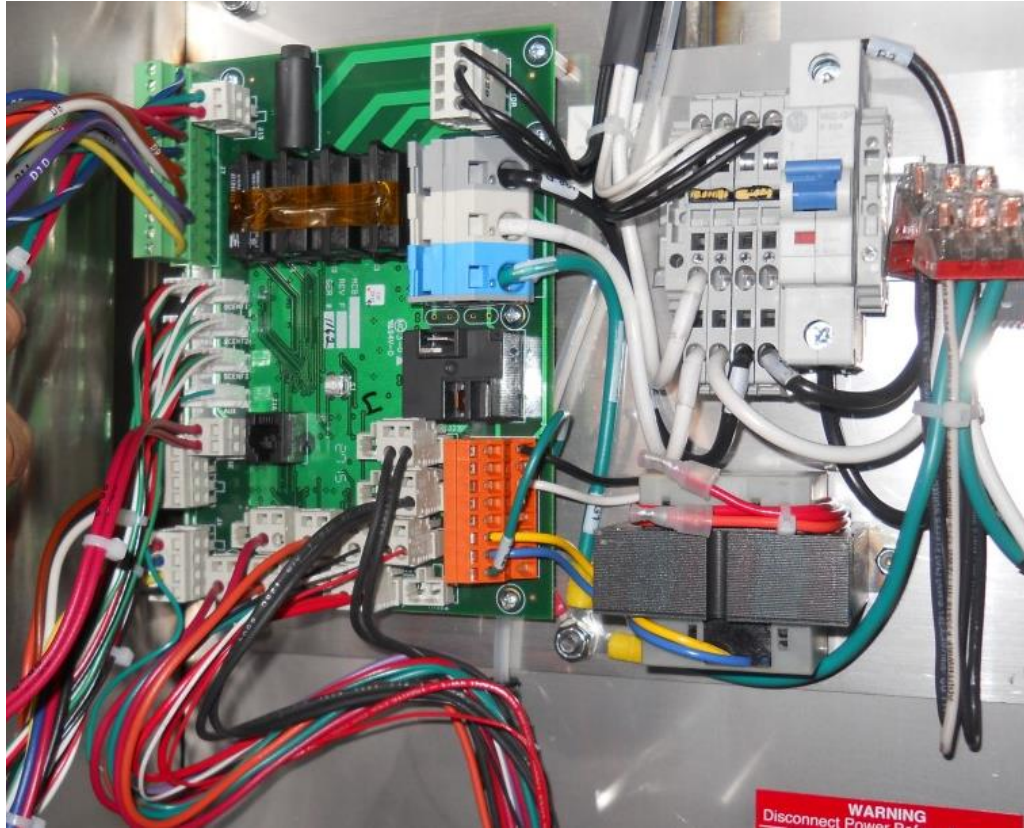

Strongly suggested taking picture of existing board in unit to reference how wires are routed when rework is complete. Cut wire ties as needed.



Step 1

**COMPRESSOR WIRE**

Important to flag top wire with tape or label as all are black and all route to top of machine. Top wire is the compressor wire and must be placed in correct (top) position on new board.

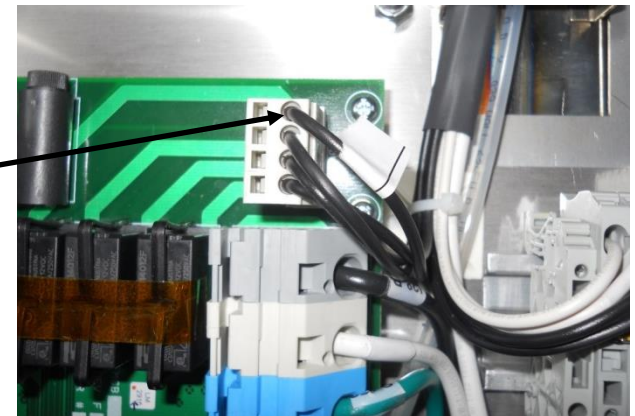

Step 2

**Step 3: Start pulling cables, using marker to label each connector with the “J” number printed on the board near the connector. Some connectors are labeled some are not. Labeling will make it a easier to reconnect to new board.**



Always pull connector to remove versus pulling on wires.

Some connectors are labeled some are not, best to label or mark to ease reinstallation on new board.

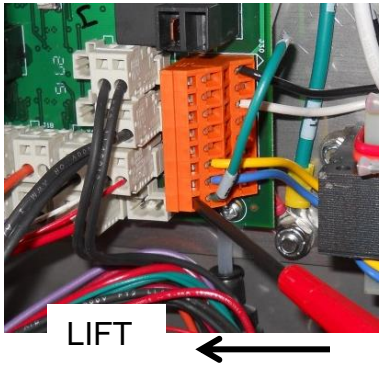
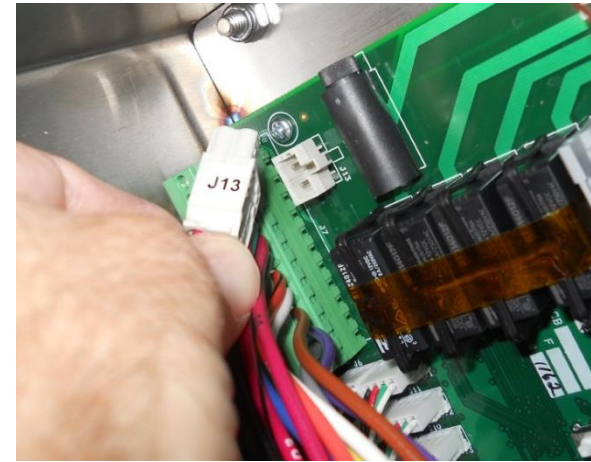

Step 4

Insert screwdriver blade in parallel to board then lift to release wire.

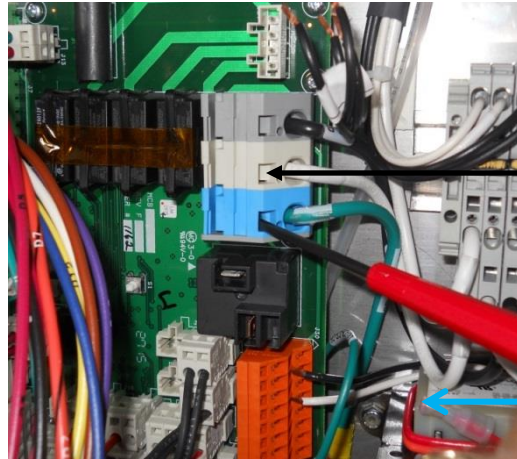
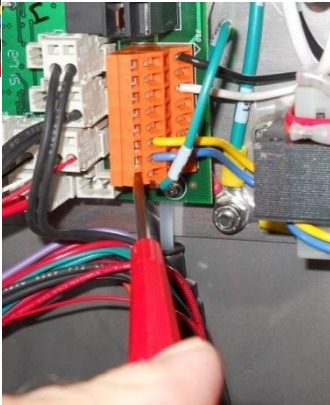

Main power connector wire removal: Insert small screw driver into square hole above wire then lift (pry) screwdriver to release tension on wire.

Step 5

LIFT



Step 6

J29 Motor connector is pulled straight up to remove but to remove wires insert small screw driver as shown, apply downward pressure and pull wire or simply cut wires at base of connector and strip 3/8”.

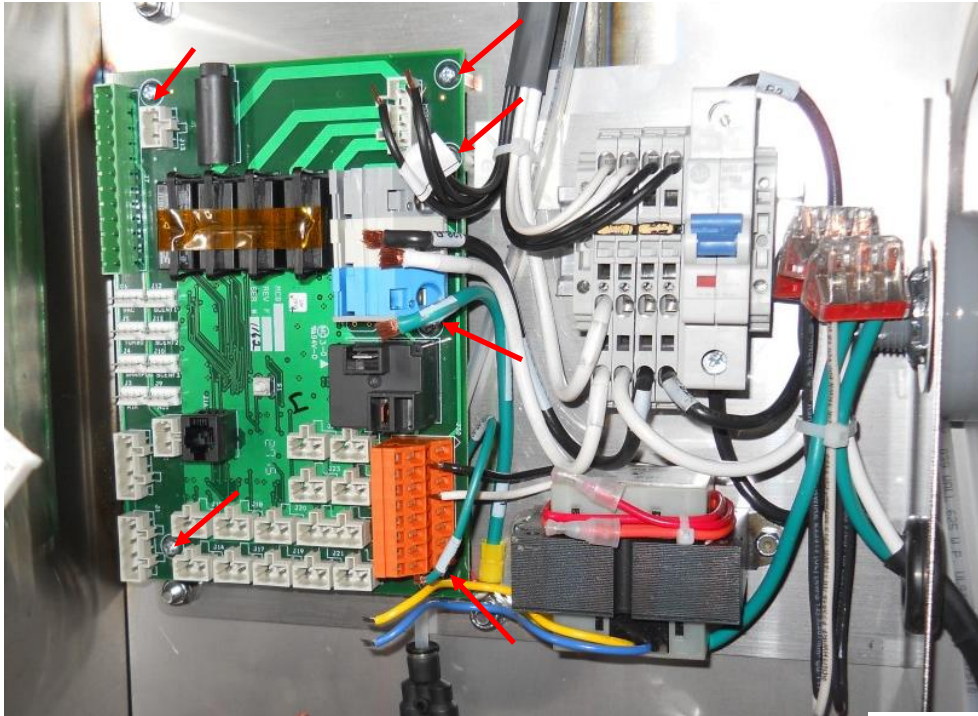

Step 7  
Remove 6 mounting screws holding board to mounting plate, remove board.



Step 9  
Remove nut from ground stud, remove shorter lighter gauge ground wire that connected to orange terminal block on old board and discard wire, then reinstall ground stud nut.

Step 8  
Remove these two standoffs from the existing mounting plate.

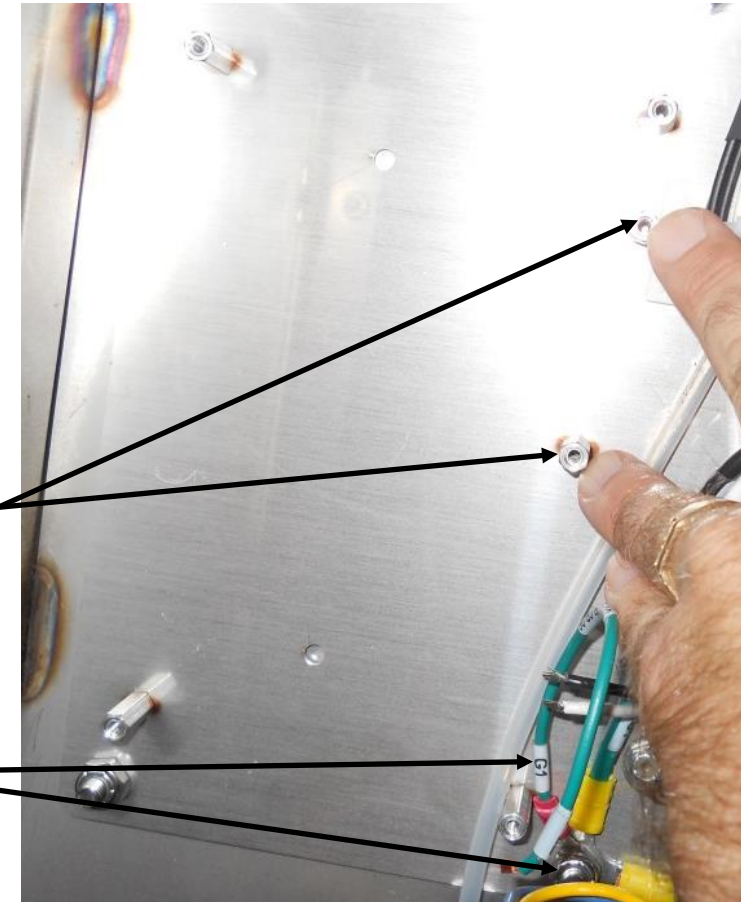

6" leads that come with Board CB-5003-RW1 are there only if existing wires are too short to reach board. Remove these leads and wire directly to board terminals if wire length will suffice. If short, use wire nuts or push on connector to terminate to 6" leads.

Step 10: Mount new board CB-5003 over (4) standoffs remaining on mounting plate (4 corners) using screws removed in previous step.

Step 11: If long enough Install wires removed from 4 pin connector at top of old board (step 6) to terminal strips according to their function printed on the new board. Note top wire in terminal strip was labeled earlier to identify compressor lead which must go to top position. Position for vacuum motors in bottom 3 terminals is not critical.

Step 12: Install incoming power (heavy gauge wires) Black wire- 'hot', White wire- 'Neutral', Green wire- 'Gnd'

Step 13: Note, in picture shown all wires could reach board except the 115Vac wires **out** to transformer. 6" leads with wire nuts or push on connectors were used.

Black and white wires came from orange connector on old board, go to transformer.

Step 14: Yellow and blue (24Vac in) from orange connector on old board go to transformer

View of old board for reference.

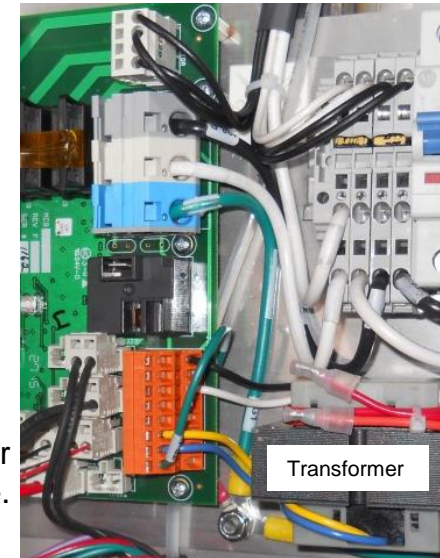
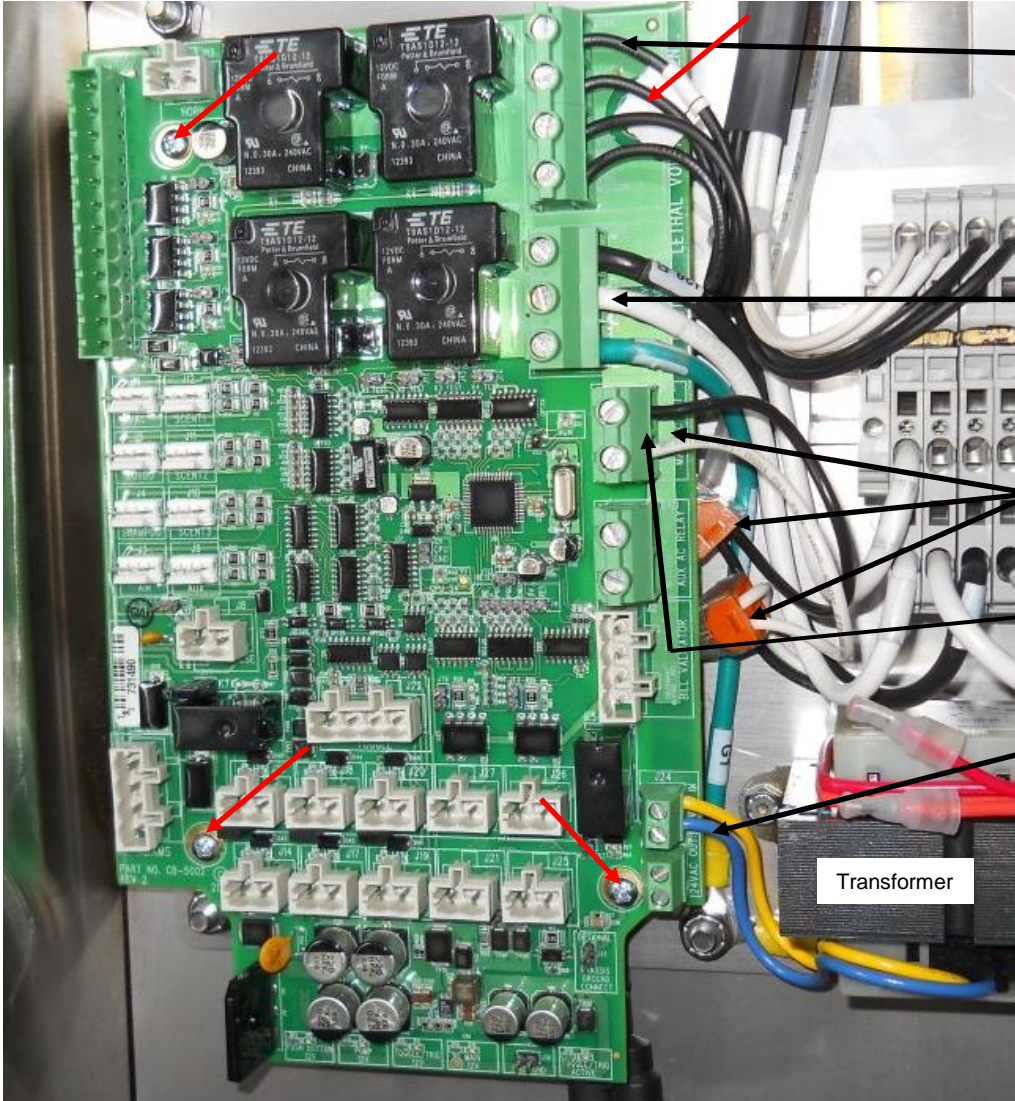

Reconnect small connectors with care, easy to bend pins. Start from bottom and work up is easiest.

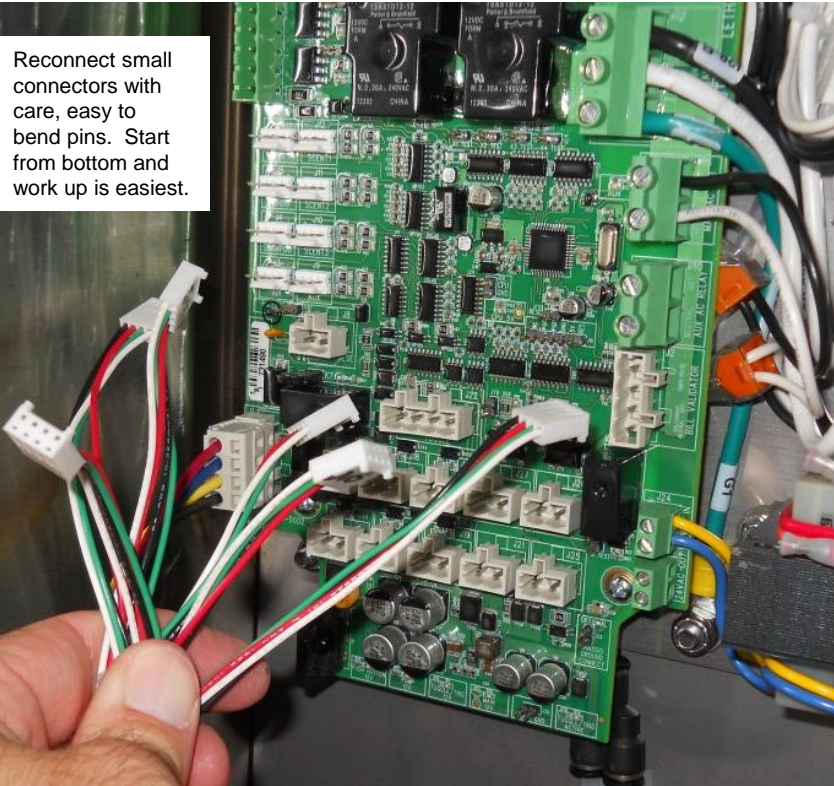

**IMPORTANT!**

Any 29000, 29001, 29002, 29003 or 29060, 29061, 29062, 29063 requires additional changes to pumps. **Page 8** explains the use of the new pump kits. The remaining pages explain the how to reuse pumps and convert electrical logic. **CRITICAL that shampoo and spot removal J20 and J18 not be plugged in until one of these rework options is complete.**

**Units without shampoo or spot remover:** (29015, 29016, 29017, 29018, 29025, 29026, 29027, 29028, 29035, 29036, 29037 and 29038) Replace all connectors matching labels on connectors to corresponding termination points printed on board. Take care with small connectors not to bend pins. Use zip ties to support wiring so as not to allow any wires to be pinched when closing door. Test unit and all it's functions, then put back into service.

**Turbo-Towel units (29050 and 29051) will have small modification to wiring , see page 7.**

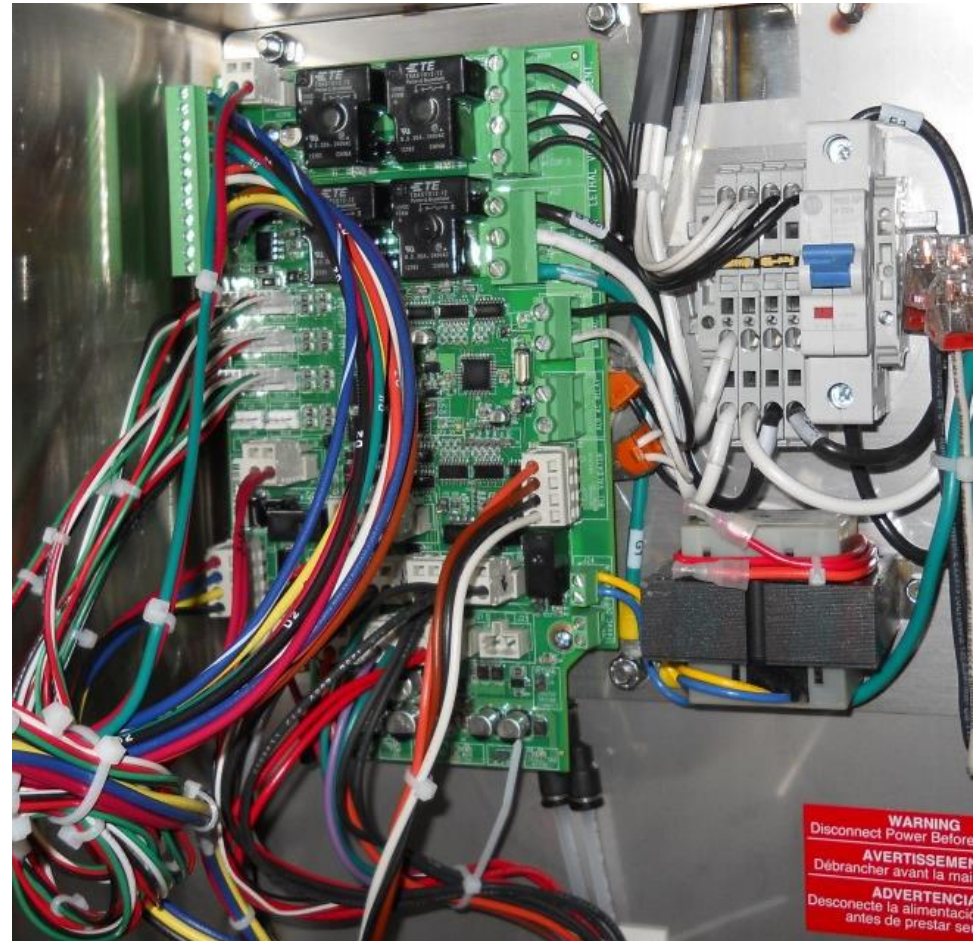

**WARNING**  
Disconnect Power Before  
**AVERTISSEMENT**  
Débrancher avant la mai  
**ADVERTENCIA**  
Desconecte la alimentació  
antes de prestar se

# Rework of 29050 and 29051 Ultra Series Vac with Turbo Towel

This rework is required for Turbo Towel models of the 29000 series only.

View inside of older 29050 control panel with CB-5002 board

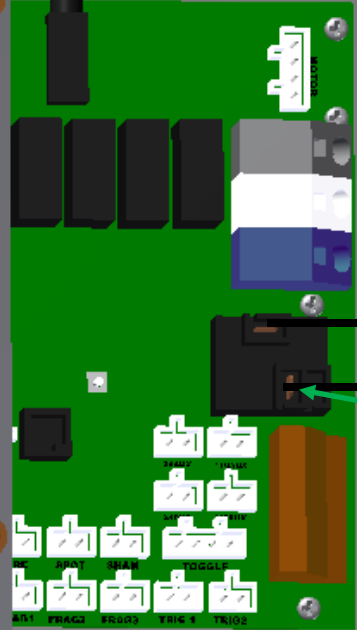

Remove white wire from circuit breaker, move to *Aux. AC Relay "Neutral"* (J40) on new CB-5003 board

View inside newly modified 29050 control panel with CB-5003 board

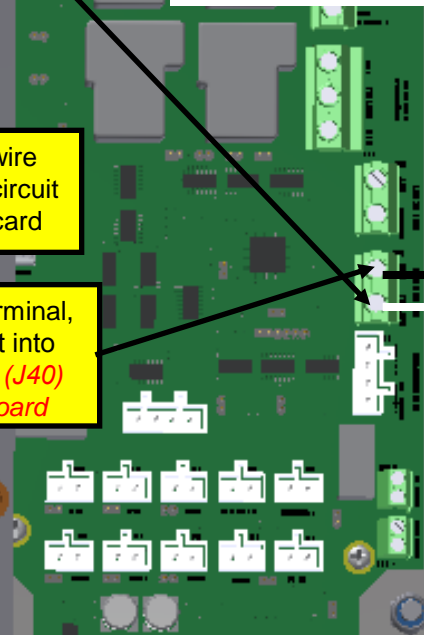

Remove black wire between relay & circuit breaker and discard

Disconnect, cut off terminal, strip wire 3/8", insert into *Aux. AC Relay "Hot"* (J40) on new CB-5003 board

This end of white wire will remain connected to relay, Pin "B"

This end of black wire will remain connected to relay, Pin "A"

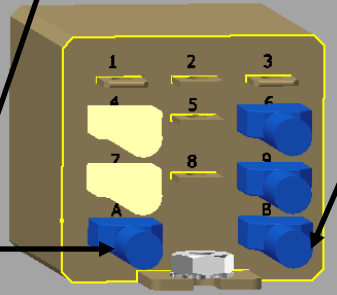

View looking at end of relay



**Rework directions for Shampoo and Spot Remover if Purchasing Pump Kits:**  
**29000-29A-5 kit for 29000, 29001, 29002, 29003.**  
**29060-29A-1 kit for 29060, 29061, 29062, 29063.**

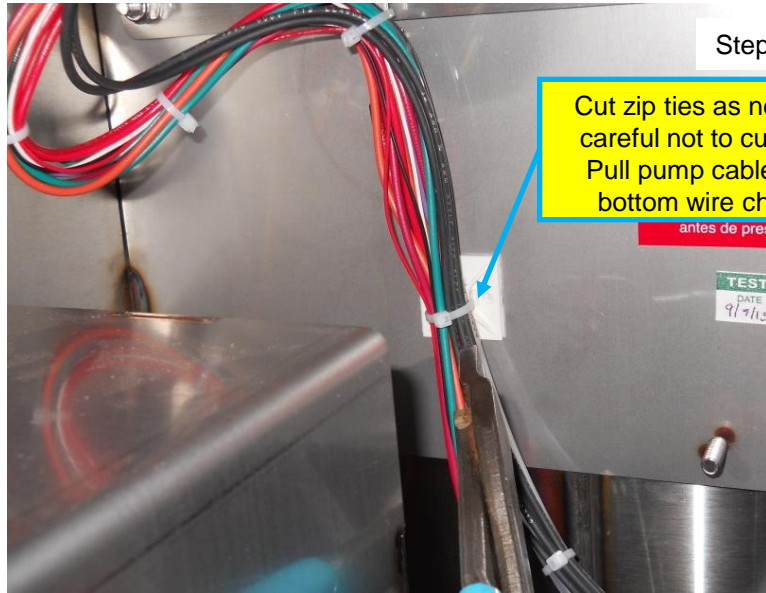

Step 1

Cut zip ties as needed, careful not to cut wire. Pull pump cables out bottom wire chase.

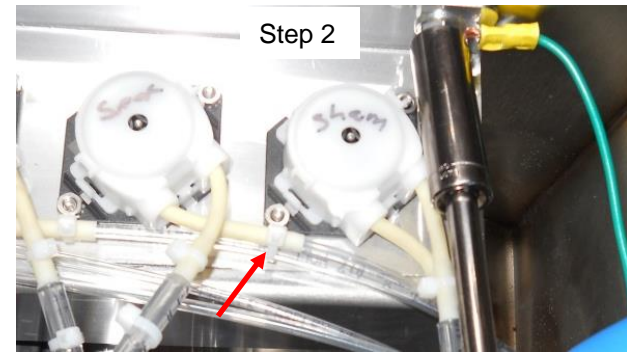
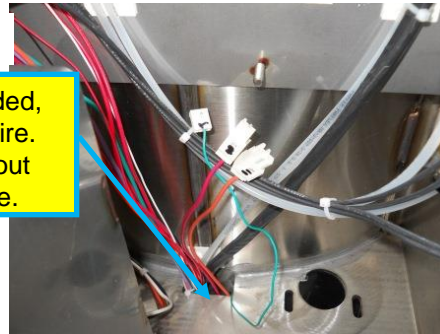

Step 2

Step 1: Pull all connectors/wires going to bottom pumps (how many will depend on which machine model) out through bottom wire channel.

Step 2: Label outgoing hoses from pumps to ease identification, cut zip ties to disconnect outgoing hoses.

Step 3: Remove pump assembly and replace with new kit, remember to replace ground wire under right side of bracket nut. Secure outgoing hoses to new pumps, clamp with small zip tie. Do not over tighten

Step 4: Route all pump connectors back up through wire chase opening and reconnect to corresponding connection point on new board. Wire tie bundle as needed.

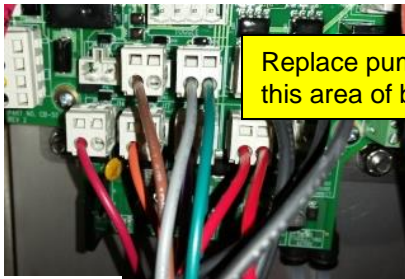

Replace pump connections this area of board.

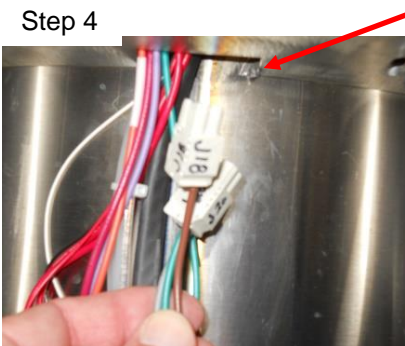

Step 4



Step 3

Cut zip tie on outgoing hoses and disconnect.

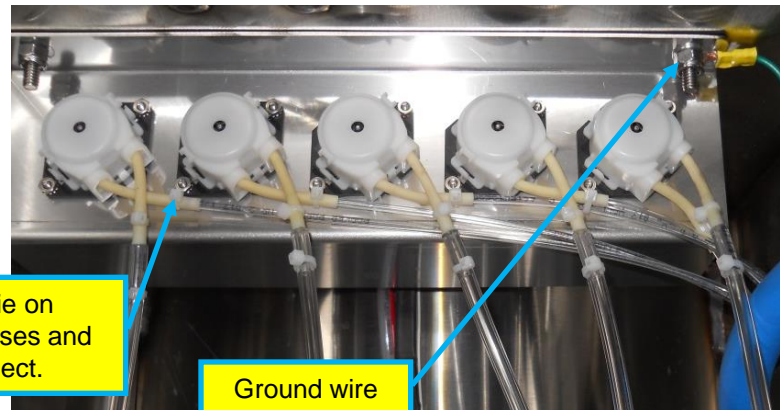

Ground wire



## Rework instructions keeping existing Shampoo and Spot Remover pumps, rewiring with (CB-03-Shamp) cable harness.

**WARNING!!! DISCONNECT ALL POWER COMING TO MACHINE BEFORE STARTING ANY WORK**

Step 1: Cut all zip ties bundling cables just below board and down to bottom section of unit where chemicals are stored. Careful not to cut wires.



Kit needed:  
CB-03-SHAMP

Step 2: Separate connectors J18 (single orange wire) and J20 (single red wire), along with smaller connector with single light gauge green wire. This connector could have been plugged into J9, J3 or J12. Pull these towards bottom of unit.



### Step 3

Using 7/16" socket remove (2) nuts holding pump bracket in place.

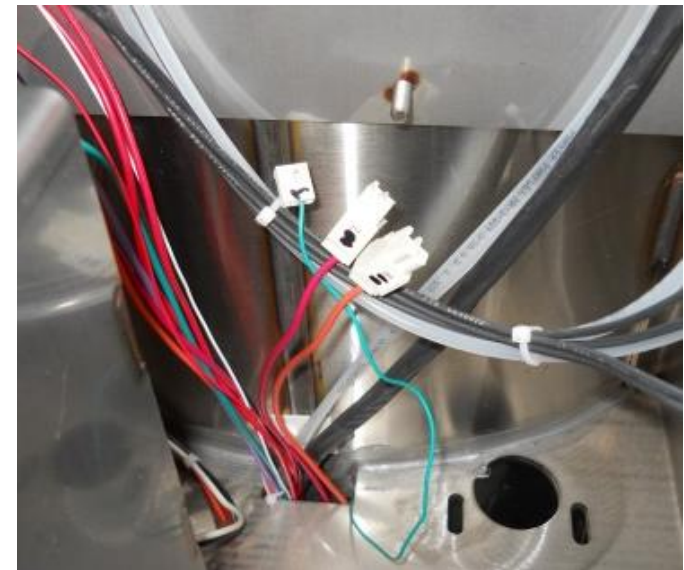

Step 4: Looking at back side of pumps and corresponding hoses identify which pump is Shampoo and which is Spot remover, label accordingly. Cut zip tie holding green wire bundle. These pumps are to the right side of unit.



Cut zip tie

Orange wire to be cut.



Red wire to be cut

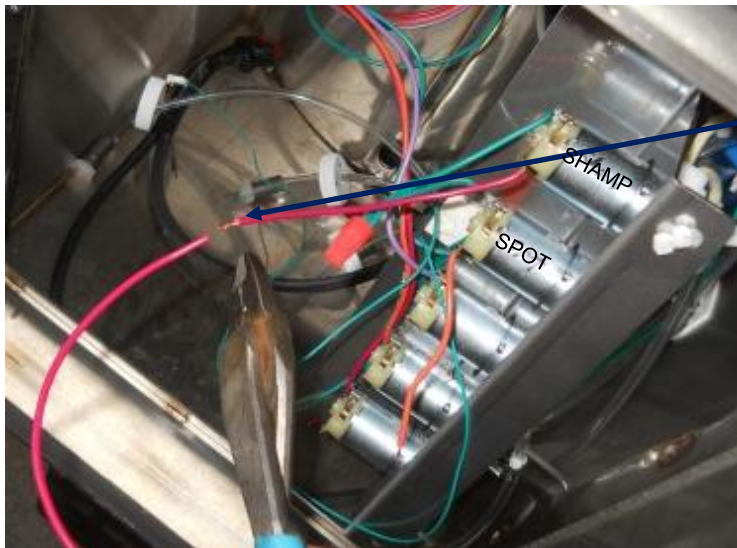

Step 5: Cut red wire coming from right pump 5" from soldered end, strip wire insulation 3/8". Discard cut wire with connector.

Step 6: Cut orange wire coming from 2<sup>nd</sup> pump from the right, cut 5" from soldered end, strip wire insulation 3/8". Discard cut wire with connector.

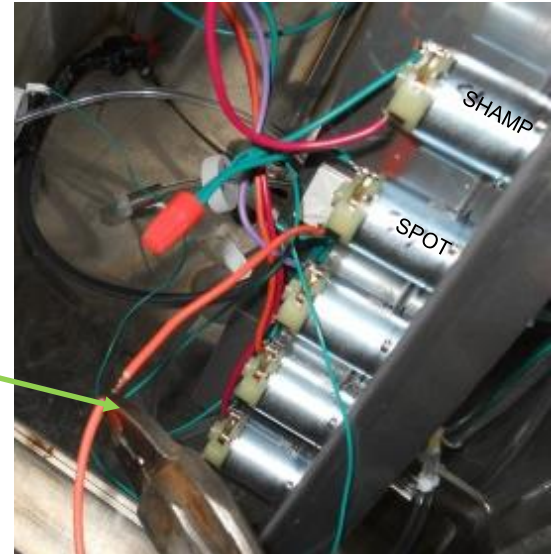

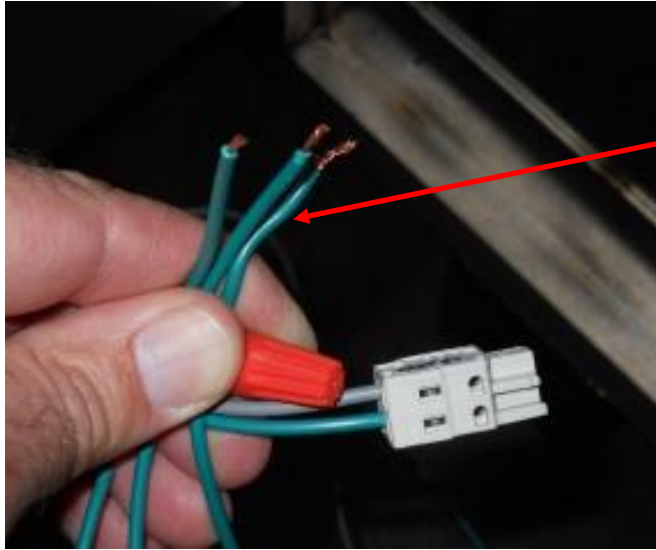

Step 7: Take the green/gray cable assembly (part of CB-03-SHAMP) and remove wire nut. Discard the (2) 6" leads from this cable assembly.

(2) 6" leads

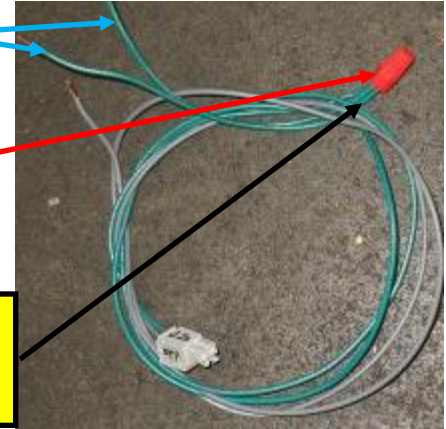

Wire nut to be removed from green wire in green/gray cable assembly

Step 8: Take the single green wire from the cable just noted above and connect to the cut and stripped red and orange wires from the Shampoo and Spot Remover pumps. Use push-on connector or wire nut. Verify connection with pull test.

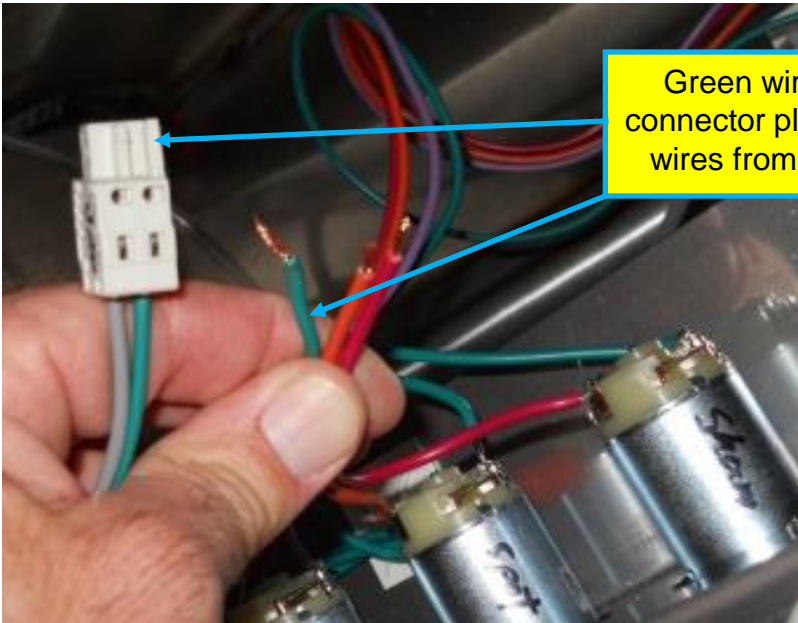

Green wire from this new connector plus red and orange wires from right two pumps

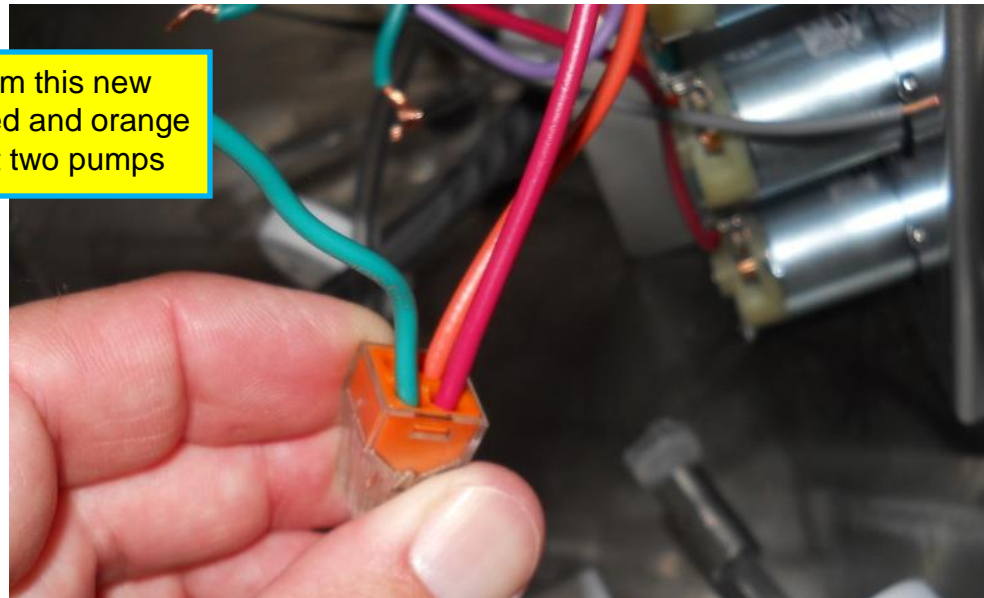

Locate wire nut that joins the (2) green wires of the right two pumps and light gauge wire to small connector.

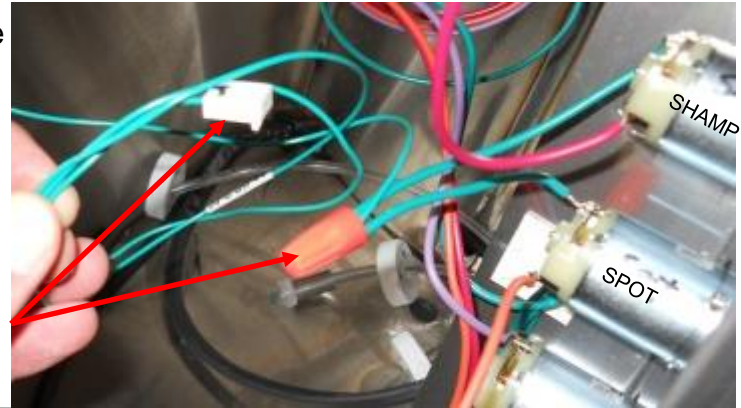

Step 9: Remove wire nut and discard light gauge green wire with connector as this is no longer needed.

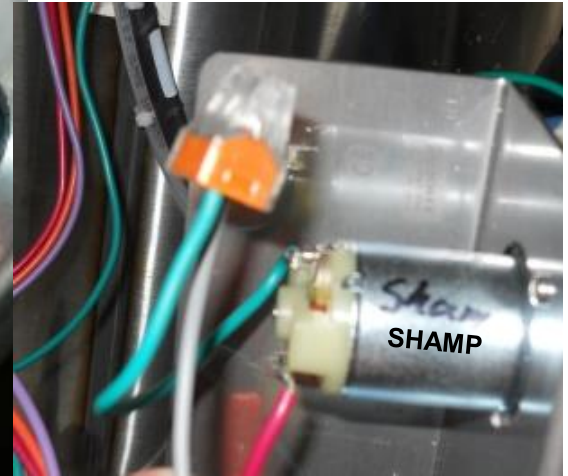
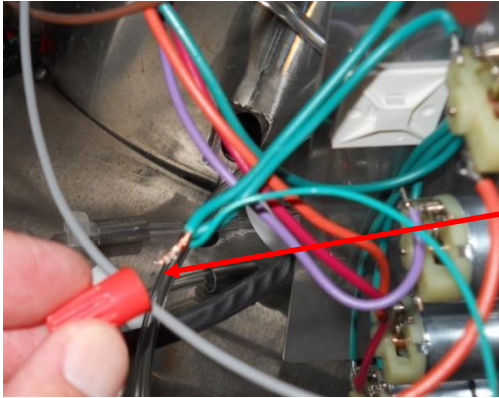

CB-03-SHAMP cable set

Step 10: Connect the **Gray** wire from CB-03-SHAMP cable set to green wire coming from Shampoo pump. Use push on connector or wire nut.

Step 11: Connect **Brown** wire from CB-03-SHAMP cable set to green wire of Spot Remover pump. Use push on connector or wire nut.

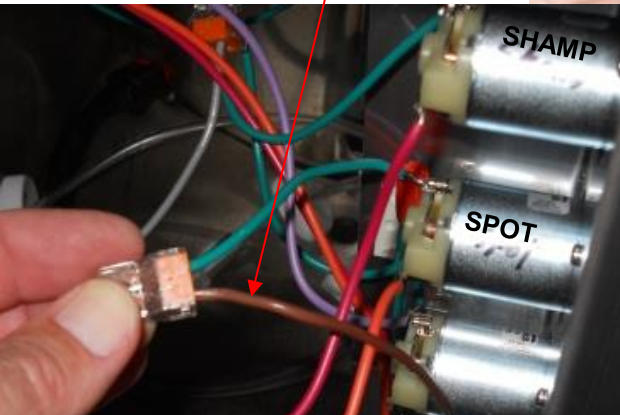

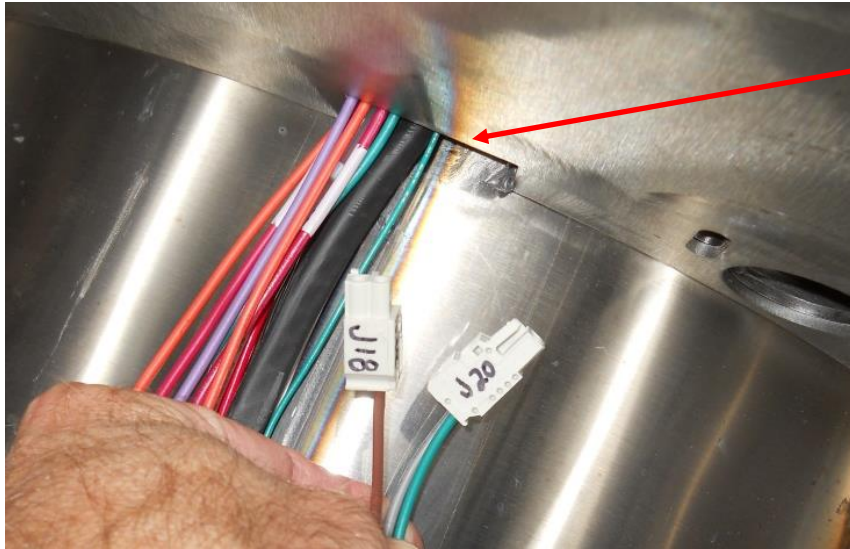

Step 12: Route the two connectors from CB-03-SHAMP cable set up through wire chase to the circuit board.



Step 13: Reconnect cables to appropriate terminals, look for labels on board.

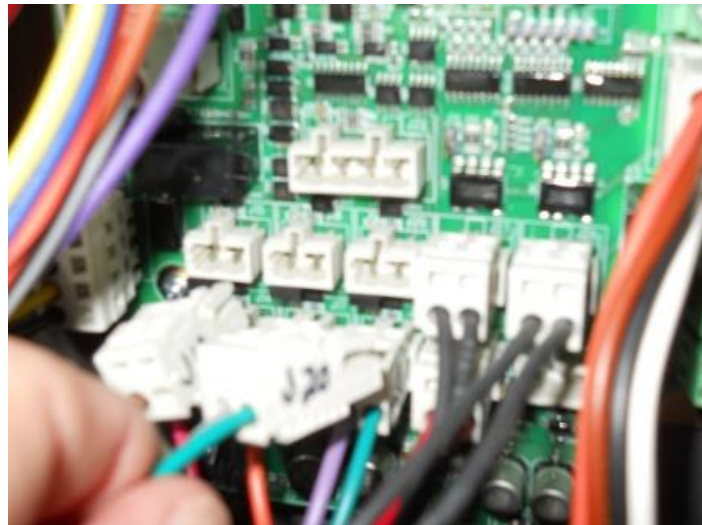

Step 14: Zip tie wire bundle as needed both in upper and lower compartment, verify loose wires can not be damaged by moving parts.

Step 15: Replace ground cable on right side of pump mounting plate, tighten nylock nuts to secure pump bracket. Test unit and put back into service.

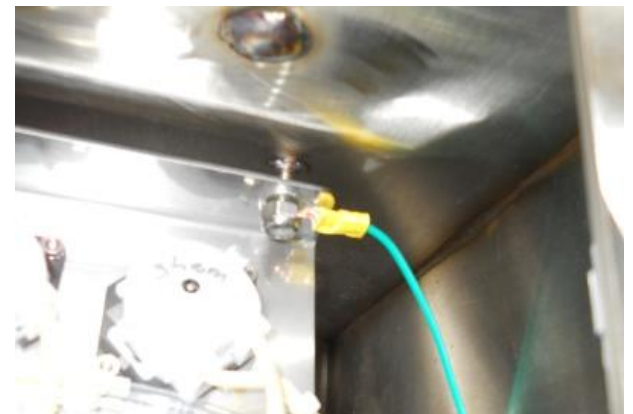

## See schematic to the right for reworking older pump wiring to new CB-5003 board.

PART NO. S29000-RW-1

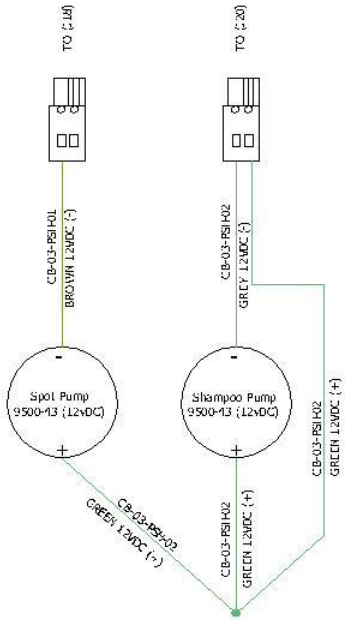

New Pump Assembly Schematic Using New Board CB-5003

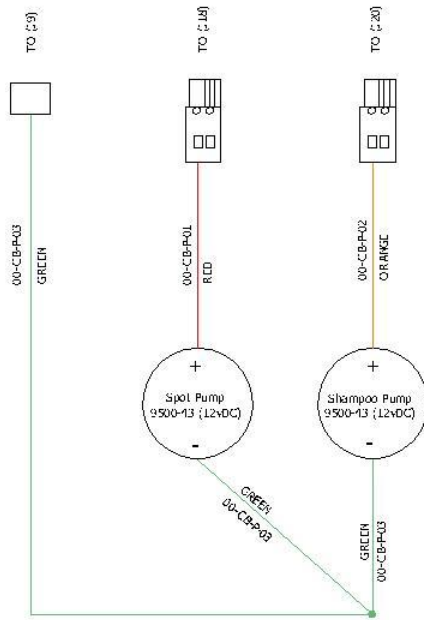

Old Pump Assembly Schematic Using Old Board CB-5002

**\*READ\*** Disconnect power to machine before any rework of electrical connections. Rework of electrical connections of Spot remover and Shampoo pumps when not purchasing rework kit with new pumps. Critical this be done before attempting to use machine. Note, wire colors may be different in older units, verify "+" molded into back of pumps before connecting.

**Step 1**  
Cut all wire ties in cable bundle going from control board to shampoo/spot remover pumps. Discard old cables going from J9, J18 and J20 on old board. Cut the (4) wires 5" from soldered joints on shampoo and spot remover pumps.

**Step 2**  
Strip 3/8" from ends of all (4) wires from shampoo and spot remover pumps.

**Step 3**  
Remove wire nut joining the (2) green wires on CB-03-PSH-02 (Note 1) discard short green wire. Connect orange wire from shampoo "+" side of pump and red wire from spot "+", and green wire from new J20 connector, wire nut all 3 wires together.

**Step 4**  
Wire nut green wire from Spot Pump "-" to new CB-03-PSH-01 cable brown wire. Wire nut green wire from Shampoo Pump "-" to CB-03-PSH-02 gray wire.

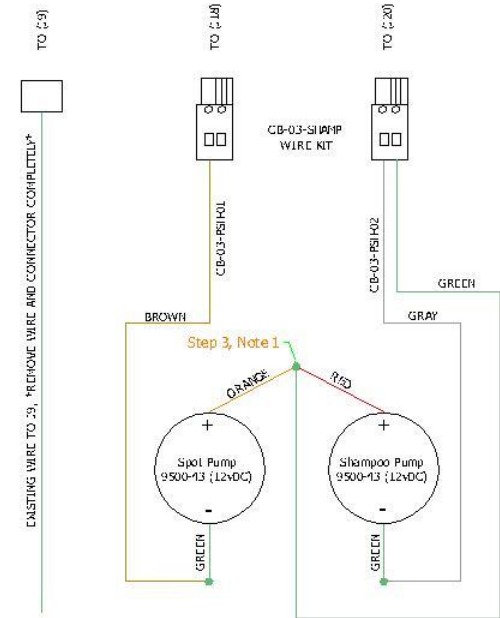

Old Pump Assembly Electrical Connections Modified to use New Board CB-5003

THIS DOCUMENT SHALL NOT BE REPRODUCED NOR SHALL THE INFORMATION THEREIN BE USED BY OR DISCLOSED TO OTHERS EXCEPT AS AUTHORIZED BY J.E. ADAMS INDUSTRIES

PART NO. S29000-RW-1



UNSPECIFIED TOLERANCES  
1 PL ±.030  
2 PL ±.010  
3 PL ±.003  
ANGLE ±1.0

TITLE <b>WIRE DIAGRAM, 29000 REWORK, PUMPS</b>			
DRAWN BY <b>MWS</b>	DATE <b>10/8/15</b>	SCALE <b>-</b>	REL. FOR PROJ. <b>-</b>
MATERIAL <b>-</b>	PART NO. <b>S29000-RW-1</b>	REV. LEVEL <b>-</b>	